



fabuwood[®]
Tips & Tricks

Fabuwood's Capabilities



In this PowerPoint you are going to learn some of Fabuwood's most quoted custom items within our standard lead time of 5-7 business days.

Our custom shop can modify your orders to create unlimited possibilities to fulfill your vision!
You Design It – We Build It!



Fill In Hinge Holes

When filling hinge holes, Fabuwood offers two options.

1. To fill hinge holes completely where it is not visible.
2. To fill hinge holes where they are slightly visible.

Both options are available and can be added to any order by sending a request to your customer service team.

Please note all cabinets, including NDW cabinets, come pre-drilled for hinge holes.



How to Create Bench Seat



- Did you know we can create Bench Seats using a stock cabinet?
 - Most bench seats are 18”H.
 - We can take a standard Drawer Base cabinet of any size and cut the first two drawers off.
 - Please note the lower drawer front in Allure is 11-1/4”H, with reveals and our toe kick (4-5/8”H) bringing your total height to 16-3/8”. When adding your cushion, this will bring your total height to roughly 18”H.
 - This way you saved on a custom cabinet and you are looking at a standard 7 business day lead time!





How to Create TP36/TP24

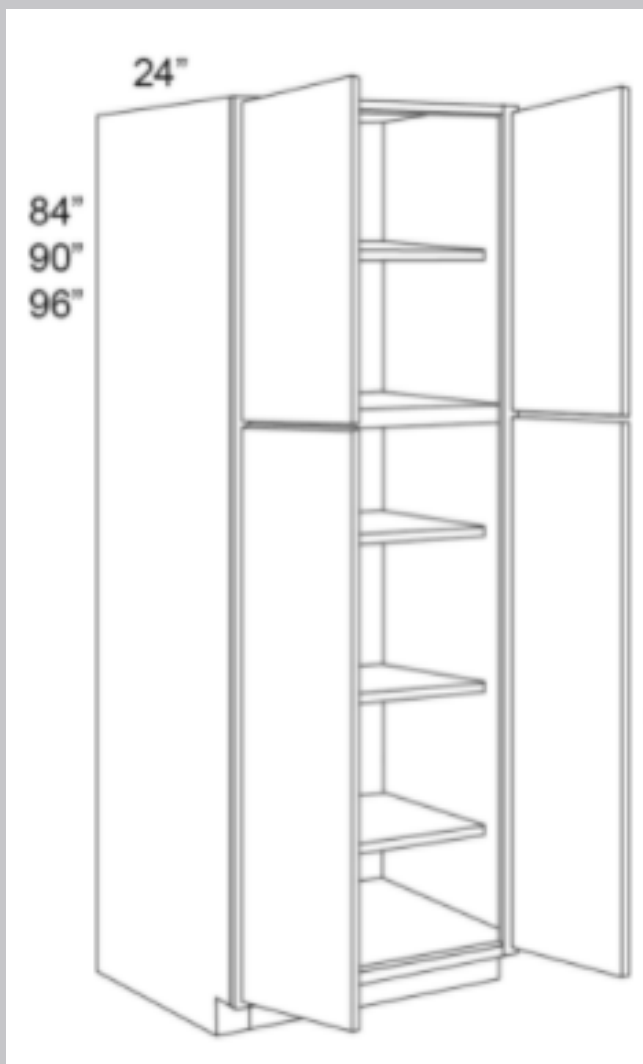

When creating a TP36" W, there are 3 options available

1. Create Tall Pantry exactly 36"W resulting in needing custom doors and incurring a 30 business day lead time.
2. Combine 2 TP18's to create a TP36, using existing TP18 doors with 1" overlay hinges.
Note: Side reveals will be 1/2" instead of 1/4".
3. Combine 2 TP18's to create 35-1/2"W TP. We can use TP18 doors with standard 1-1/4" overlay hinges and side reveals will be 1/4".

When creating a TP12" W, There are 3 options available:

1. Create Custom TP12 using custom lower door. This will incur a 30 business day lead time.
2. Take a TP24, cut width to 12"W, using 1 set of TP24 doors with 1-3/8"H overlay hinges, side reveals will be 1/8".
3. Cut width to 12-1/4"W using 1 set of TP24 doors with standard hinges, side reveals will be 1/4"

Cut a Wall Cabinet in Half to create 2



Let's imagine you need a W1818.

We could take a W2118 and cut the width or we can take a W3618 and cut it into two cabinets and use the existing doors from a W3618.

If we cut W3618 in half to create 2 W1818:

- W3618 Doors are 17-3/4"W each.
- If we use existing doors from W3618, please note reveal will be 1/8"W
- This way will incur a 7 business day lead time.





Flip Frame on Base/Tall Cabinet

- We can flip the frame on any base cabinet size to have the doors on top and a drawer at the bottom.
 - This would incur a custom shop fee as well as a 7 business day lead time.
- We can also flip a Tall Pantry Cabinet to have the tall door on the top and the small door on the bottom.
 - This would incur a custom shop fee as well as a 7 business day lead time.





Create a Broom Closet

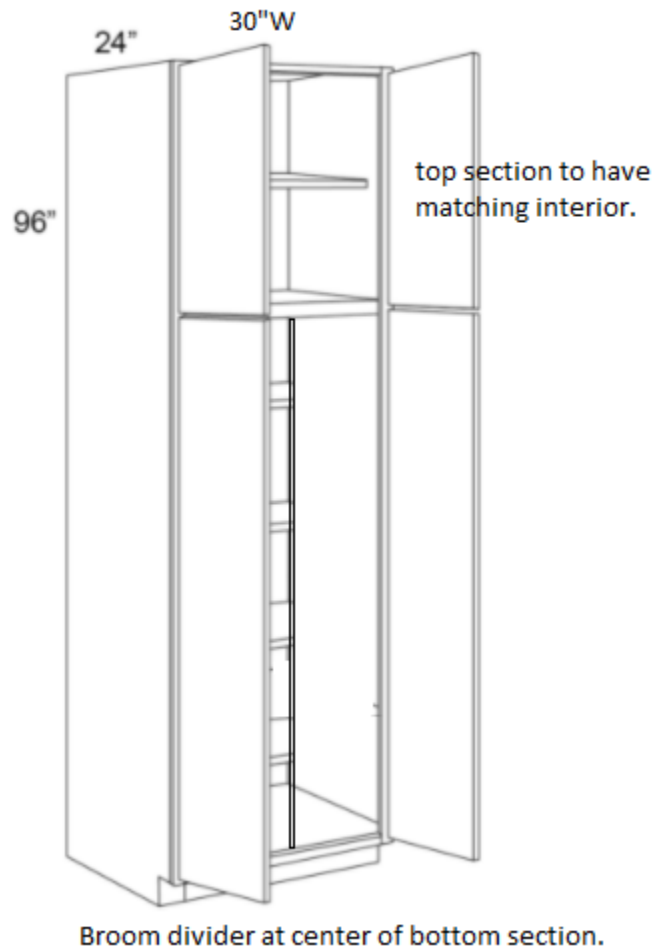

We can create a broom closet with 2 options.

1. We can remove the fixed shelf, fill in the groove, and connect the top and bottom doors with dowels.
Note: The original groove will be filled but still visible.
2. We can insert divider and make a cut out on the fixed shelf to accommodate a broom. You would specify the cut out size needed as well as the left/right side.

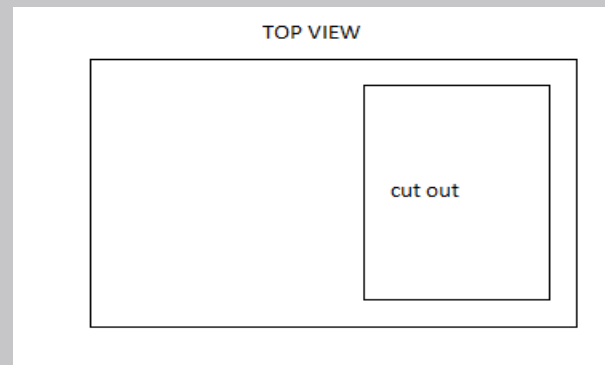



Oversized Panels, Fillers, & Returns

- Fabuwood can create any oversized panel, fillers, with or without a return and we can create custom columns.
 - Be sure to specify width, height & depth

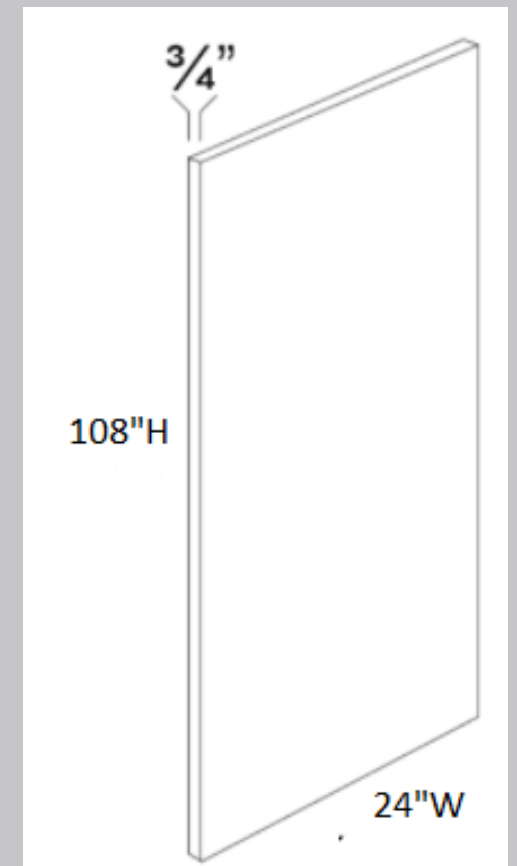
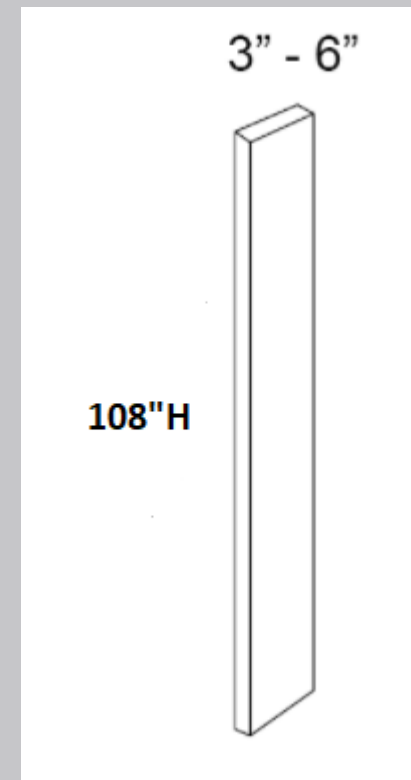
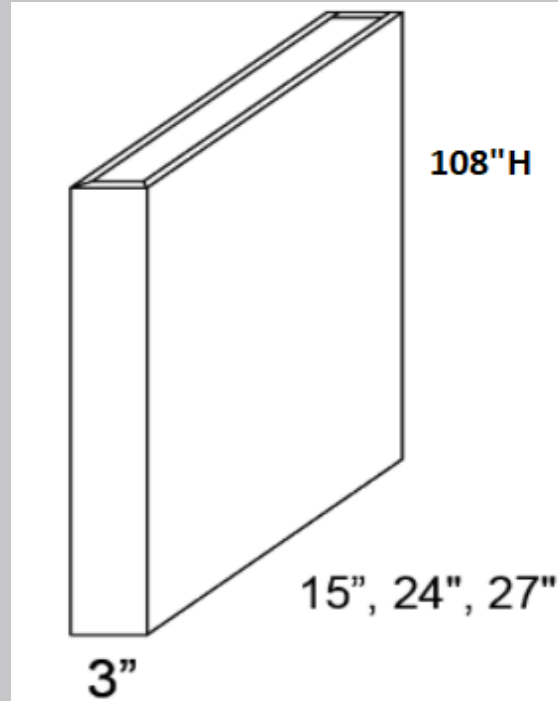



Toe Kick Drawer

We can take any Base & Drawer Base Cabinet and add a toe kick drawer.

- This is especially beneficial for sink base cabinets, so storage space is not lost.

Curio Cabinet



Fabuwood's Custom Shop can take any corner wall cabinet as well as any wall cabinet and create a curio cabinet.

- We remove the side panel and add a frame and door with a cut door modification!
- Image to the right is from KBIS 2022 – Onyx Frost!



Base Cabinet Single Door Using WP-BASE

Fabuwood can take a B24 or W2430 and create a single full height door using a WP-BASE. Our WP-Base is 23-1/2"H x 29-1/2"H.

*Please see an example of this from KBIS 2022 featuring our Fusion Kona & Oyster!



Create BMC

Did you know Fabuwood can create a BMC with any stock drawer front size?

- Most commonly used are 6-3/4”H or 11-1/4”H. BMC standard drawer front height is 9”H.
- BMC ‘s are offered in 24”W & 30”W.

Let’s say you need a BMC36 and instead of 9”H drawer front at the bottom you are okay with 11-1/4”H. We can take a DB36 and create BMC. This will incur a custom shop fee and have a 7-business day lead time!



Stacked Cabinets

Fabuwood can stack any 2 cabinets together. Once stacked, if indicated Fabuwood will finish exposed sides to appear as one cabinet.

- If stacked on site, stacked molding can be installed in between stacked cabinets to give a nice flushed appearance.





Entering Custom Stock Colors 60 Business Day Lead Time

Door Style 1
GALAXY FROST

Custom Upgrades:
 Finishing

Assembled

[Change Style](#) [Duplicate](#) [Delete](#)

Custom Upgrades:
 Finishing

Color:
INDIGO

[Add New Style](#)

Custom Upgrades:
 Finishing

Color:

- BLANC
- DOVE
- FROST
- INDIGO
- IVORY
- LINEN
- NICKEL
- OYSTER
- SLATE
- STONE

Assembled

[Change Style](#) [Duplicate](#) [Delete](#)

#	Qty	Item	Description
1	<input type="text" value="1"/>	TK8	TOE KICK 96
2	<input type="text" value="1"/>	CM-3	SMALL COVE CROWN MOLDING 96
3	<input type="text" value="1"/>	TOUCH UP KIT	TOUCH UP KIT FOR STYLE

- When entering a quote, add a style and color, select Finishing under Custom Upgrades and select a stock color adding all cabinets with exposed sides.
- Once this is complete, add a new style and color and select Galaxy Indigo (the color you selected for finishing upgrade) and add all accessories such as toe kick, crown molding, wainscot panels, etc. This is where you will also add a touch up kit.
- Note: If you add a touch up kit under your first style it will come in as the original style and color; ie Galaxy Frost
- This will also save the dealer finishing upcharges under the accessories as well!



fabuwood®